

### Benefits

- Replace Bipolar with Unipolar Rectifiers
- Essentially No Switching Losses
- Higher Efficiency
- Reduction of Heat Sink Requirements
- Parallel Devices Without Thermal Runaway

### General Features

- 1700-Volt Schottky Rectifier
- Zero Reverse Recovery Current
- Zero Forward Recovery Voltage
- High-Frequency Operation
- Temperature-Independent Switching Behavior
- Extremely Fast Switching
- Halogen-Free; RoHS Compliant

### Application

- Switch Mode Power Supplies (SMPS)
- Boost diodes in PFC or DC/DC stages
- Free Wheeling Diodes in Inverter stages
- AC/DC converters

$V_{RRM} = 1700\text{ V}$   
 $I_F, T_C < 135^\circ\text{C} = 14.4\text{ A}$   
 $Q_c = 96\text{ nC}$

### Package TO-247-2

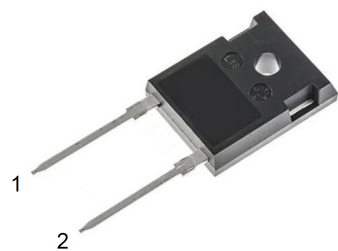

### Equivalent Circuit



### Absolute Maximum Ratings ( $T_A=25^\circ\text{C}$ unless otherwise noted)

Parameter	Symbol	Value	Unit
Repetitive Peak Reverse Voltage	$V_{RRM}$	1700	V
Surge Peak Reverse Voltage	$V_{RSM}$	1700	V
DC Blocking Voltage	$V_{DC}$	1700	V
Forward Current $T_C \leq 135^\circ\text{C}$	$I_F$	14.4	A
Non-Repetitive Forward Surge Current $T_C=25^\circ\text{C}, t_p=10\text{ ms, Half Sine Wave, D}=1$ $T_C=110^\circ\text{C}, t_p=10\text{ ms, Half Sine Wave, D}=1$	$I_{FSM}$	55	A
		41	A
Repetitive Peak Forward Surge Current $T_C=25^\circ\text{C}, t_p=10\text{ ms, Half Sine Wave, D}=1$ $T_C=110^\circ\text{C}, t_p=10\text{ ms, Half Sine Wave, D}=1$	$I_{FRM}$	45	A
		26	A
Power Dissipation $T_C=25^\circ\text{C}$ $T_C=110^\circ\text{C}$	$P_{tot}$	231	W
		100	W
Maximum Case Temperature	$T_C$	135	$^\circ\text{C}$
Operating Junction Range	$T_J$	-55 ~ +175	$^\circ\text{C}$
Storage Temperature Range	$T_{stg}$	-55 ~ +135	$^\circ\text{C}$
TO-247 Mounting Torque	M3 Screw	1	Nm
	6-32 Screw	8.8	lbf-in

### Electrical Characteristics

Symbol	Parameter	Condition	Min	Typ	Max	Unit
$V_F$	Forward Voltage	$I_F = 10A, T_J = 25^\circ C$	--	1.7	2.0	V
		$I_F = 10A, T_J = 175^\circ C$	--	3.0	3.5	V
$I_R$	Reverse Current	$V_R = 1700V, T_J = 25^\circ C$	--	20	60	$\mu A$
		$V_R = 1700V, T_J = 175^\circ C$	--	100	300	$\mu A$
$Q_C$	Total Capacitive Charge	$V_R = 1700V, I_F = 10A$ $di/dt = 200A/\mu s, T_J = 25^\circ C$	--	96	--	nC
$C$	Total Capacitance	$V_R = 0V, T_J = 25^\circ C, f = 1MHz$	--	827	--	pF
		$V_R = 200V, T_J = 25^\circ C, f = 1MHz$	--	78	--	pF
		$V_R = 800V, T_J = 25^\circ C, f = 1MHz$	--	41	--	pF
$R_{\theta JC}$	Thermal Resistance from Junction to Case		--	0.65	--	$^\circ C/W$

### Typical Performance

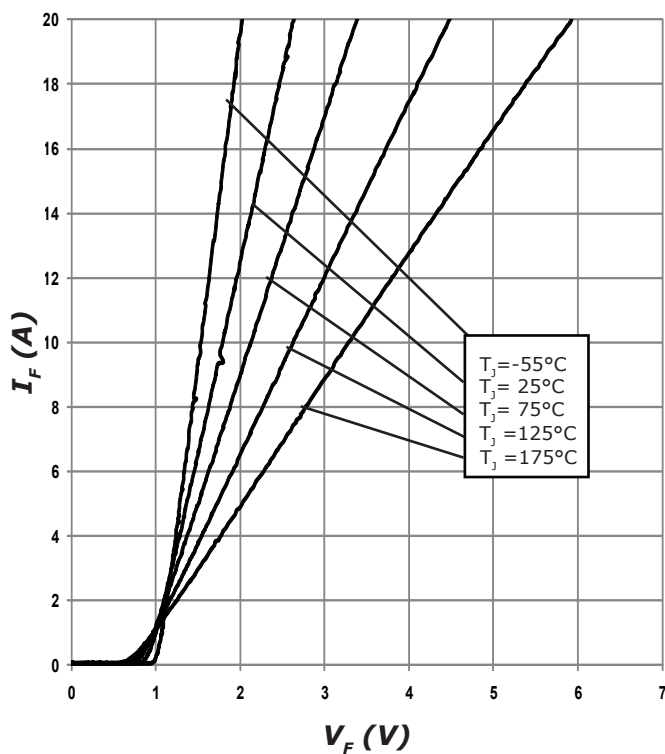

Figure 1. Forward Characteristics

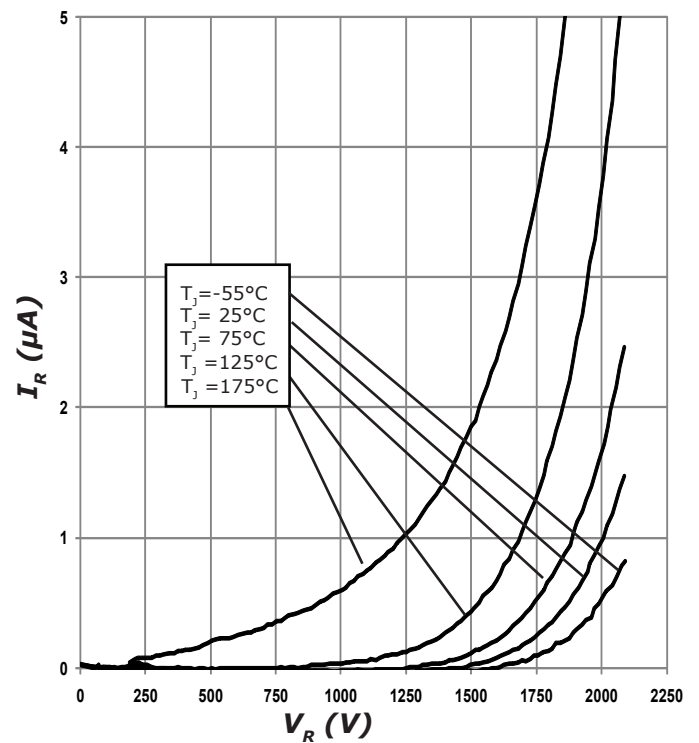

Figure 2. Reverse Characteristics

## Typical Performance

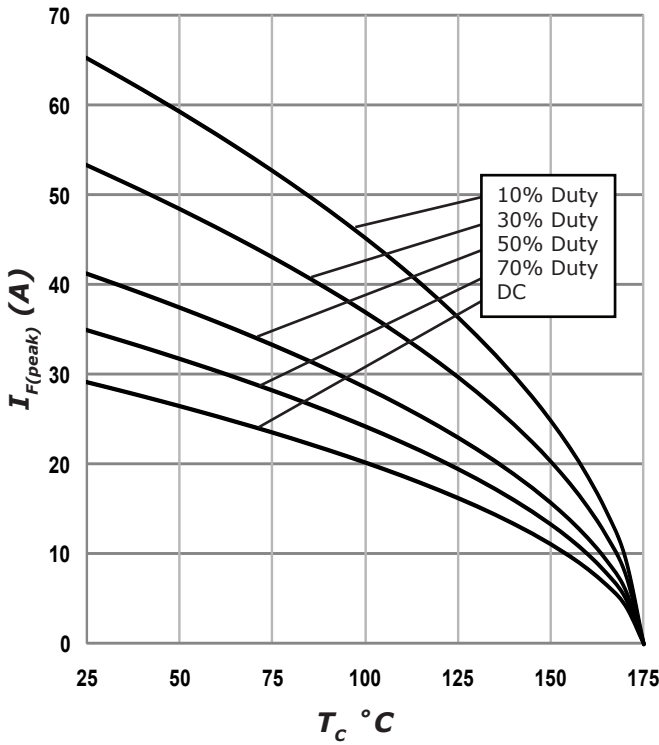

Figure 3. Current Derating

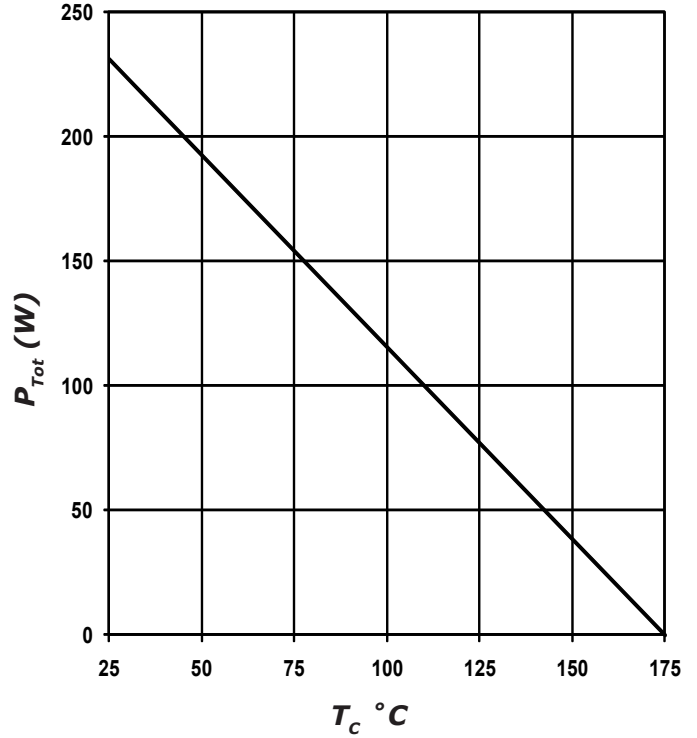

Figure 4. Power Derating

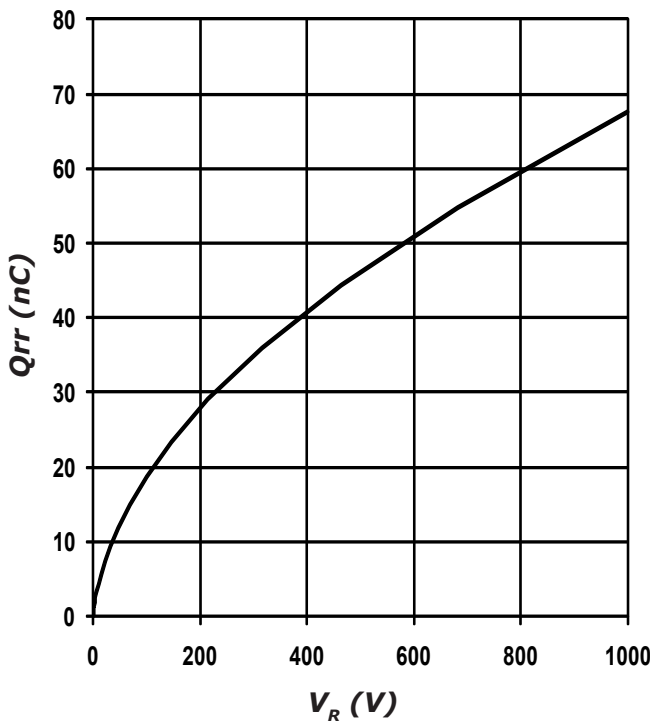

Figure 5. Recovery Charge vs. Reverse Voltage

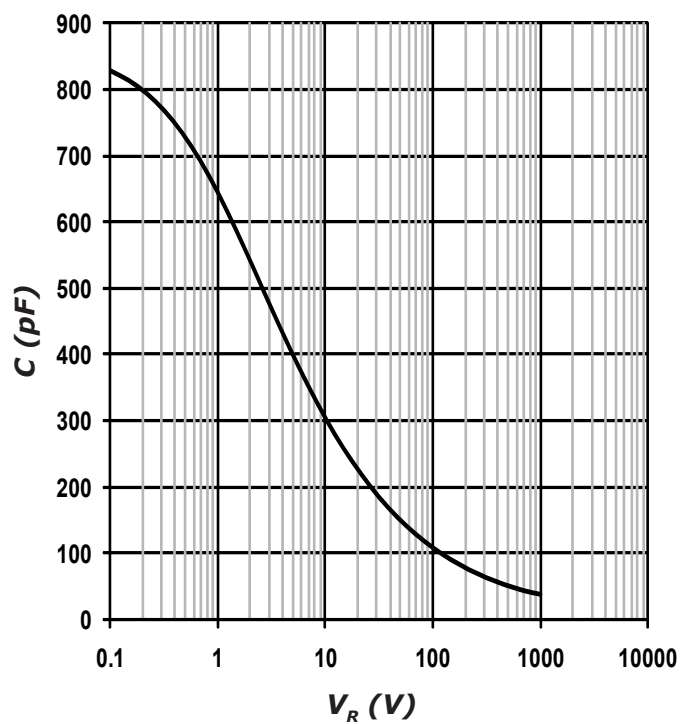

Figure 6. Capacitance vs. Reverse Voltage

## Typical Performance

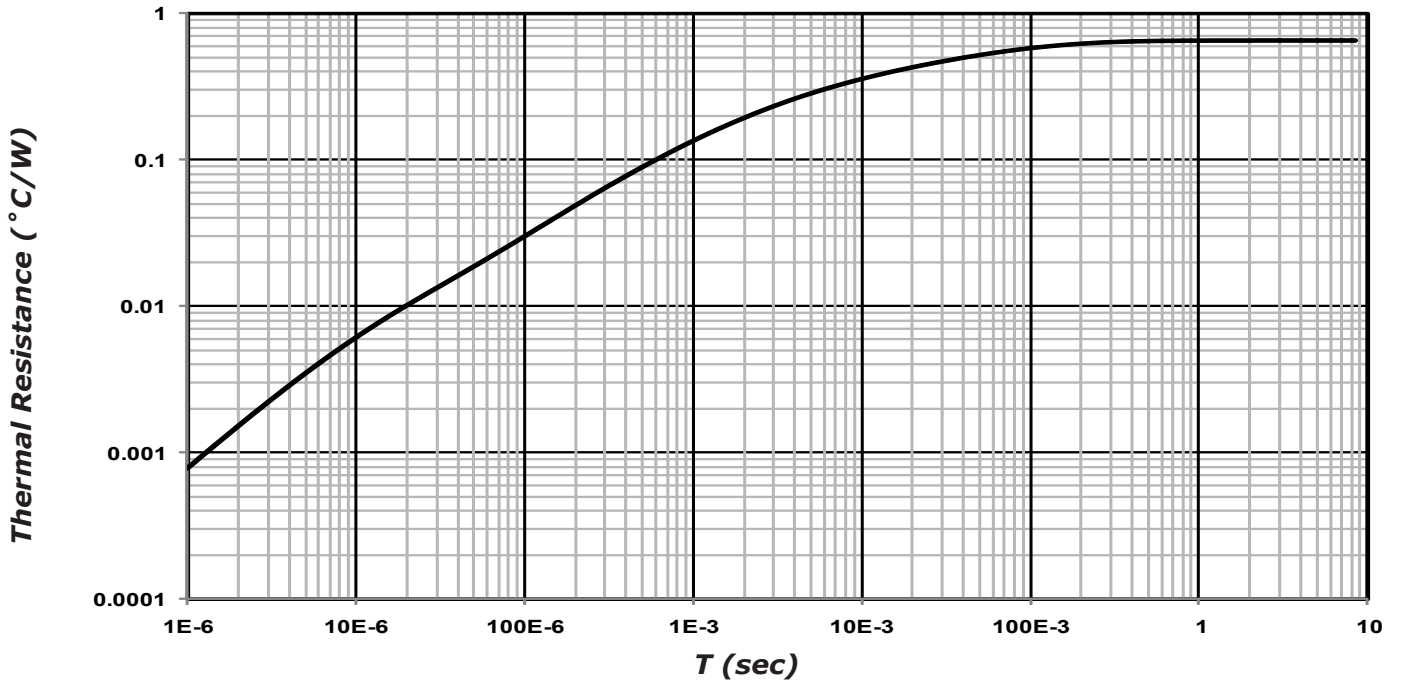
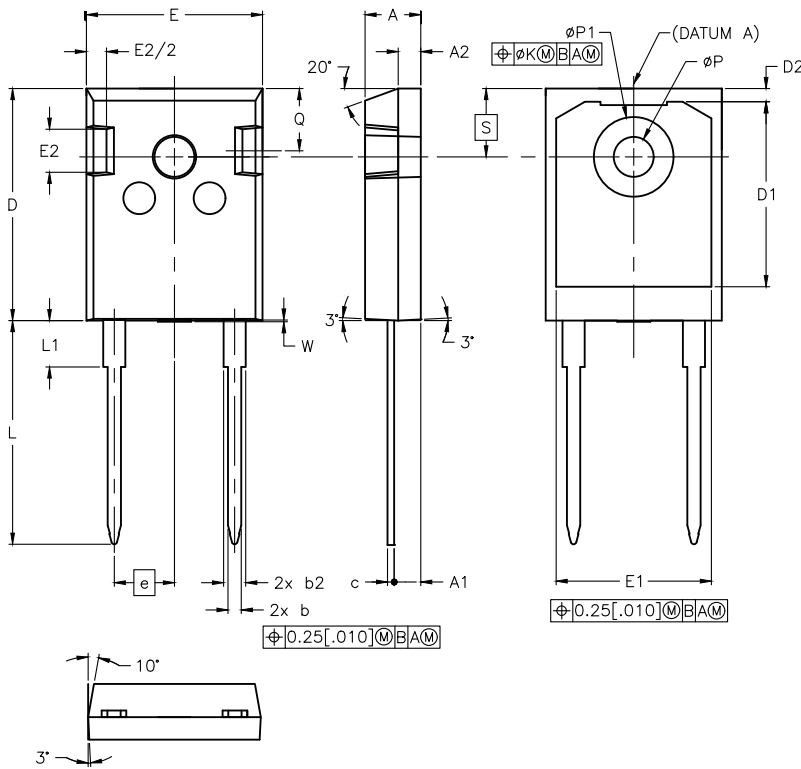

Figure 7. Transient Thermal Impedance

## Outline Drawing

### TO-247-2 Package Outline Dimensions



POS	Inches		Millimeters	
	Min	Max	Min	Max
A	.190	.205	4.70	5.31
A1	.087	.102	2.21	2.59
A2	.059	.098	1.50	2.49
b	.039	.055	0.99	1.40
b2	.065	.094	1.65	2.39
c	.015	.035	0.38	0.89
D	.819	.845	20.80	21.46
D1	.515	-	13.08	-
D2	.020	.053	0.51	1.35
E	.620	.640	15.49	16.26
E1	.530	-	13.46	-
E2	.135	.157	3.43	3.99
e	.214		5.44	
ØK	.010		0.25	
L	.780	.800	19.81	20.32
L1	-	.177	-	4.50
ØP	.140	.144	3.56	3.66
ØP1	.278	.291	7.06	7.39
Q	.212	.244	5.38	6.20
S	.243		6.17	
W	-	.006	-	0.15

## Recommended Solder Pad Layout

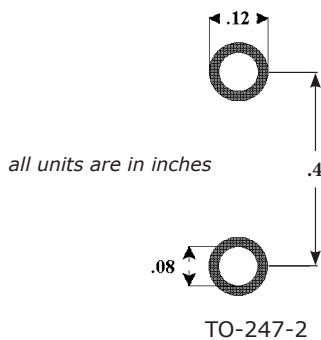

## Diode Model

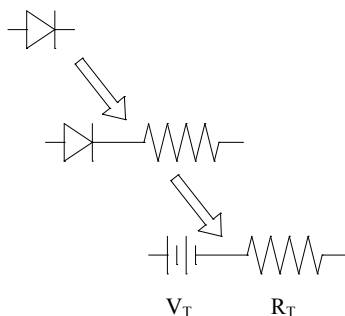

$$V_f = V_T + I_f \cdot R_T$$

$$V_T = 0.975 + (T_J - 175) \cdot 1.71 \cdot 10^{-3}$$

$$R_T = 0.053 + (T_J - 175) \cdot 1.1 \cdot 10^{-3}$$

Note:  $T_J$  = Diode Junction Temperature In Degrees Celsius, valid from 25°C to 175°C